

900 SERIES FOLDING & NESTING TABLES

SPECIFICATIONS

FOLDING TABLES

TOPS

- 1/8" thick, constructed of 45 lb particle core
- Choice of H.P. plastic laminate surface or melamine thermally fused surface
- Choice of edge treatment:
 - P.V.C. edge
 - Oak or maple edge (in natural finish with catalyst lacquer)
 - Poly-resin seamless edge

925 SERIES

- Constructed of 16 gauge
- 2" dia column
- Foot is 7/8" x 1 3/4" oval shape
- C/w adjustable glides

930 SERIES

- Constructed of 16 gauge tubular steel
- 1 3/4" dia column and foot
- C/w bullet end caps
- C/w adjustable glides

FOLDING MECHANISM

- Constructed of aluminum and nylon injection molded body
- Single press down to release
- Positive lock, up and down
- Black finish

950 / 965 / 970 SERIES

- Folding legs are secured by heavy duty bolt hinges to 1/8" thick steel support stretchers
- C/w heavy duty rubber bumper feature for stacking of tables
- Folding mechanism has heavy duty, positive quick lock action, spring loaded for easy set-up or knock down
- C/w spring securing device for securing legs when in a down position

MODEL 950

- Folding leg (double column design)
- Constructed of 1 1/2" dia x 16 gauge tubular steel, c/w adjustable glides

MODEL 965

- Four leg, folding design
- 1 1/2" dia x 16 gauge tubular steel, c/w adjustable glides

MODEL 970

- Single column folding T-leg, 1 1/2" dia x 16 gauge tubular steel, c/w adjustable glides

NESTING TABLES

985 SERIES

TOP

- 3/4" thick
- 45 lb particle core
- H.P. plastic laminate surface
- C/w balance sheet
- 3mm PVC edges

FRAME

- Constructed of 1" x 1" x 16 gauge tubular steel
- C/w welded end caps
- All welds are ground smooth and polished to a flawless finish
- C/w nylon glide caps
- Finished in polished chrome

TUFF-EDGE^{INC.}

108 Carnforth Road
North York, Ontario
M4A 2L4

T. 416.757.8201
F. 416.757.4438
Toll Free. 1.877.846.5854
sales@tuff-edge.com

www.**TUFF-EDGE**.com

Printed in Canada

DP 34044

900 SERIES FOLDING & NESTING TABLES

- Folding tables for banquet, catering, meeting and training room applications
- Features folding mechanism, with a positive lock, in folded or unfolded position



930
• 60" long table
folded position



925
• 48" long table in folded position



925



950



970



930



950
• Folding table with optional
removable modesty panel



965



930
• Folding table with optional
removable modesty panel

OPTIONAL

- Modesty panels
- Castors for mobility
- Vertical & horizontal wire management
- Power & data top access units

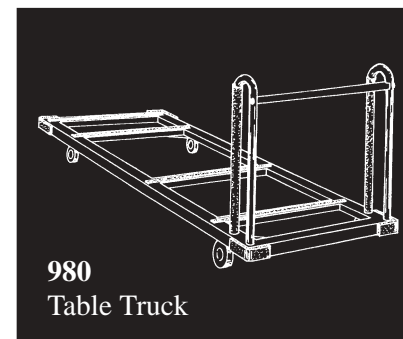

980
Table Truck



990
Table Truck



985
Nesting Tables
• Nests eight high
• Optional table truck